

ATMEL user guide manual MULTIM

MUAVIS
www.muvis.com



TABLE OF CONTENTS

General information	3
Product description	6
Contents of the package	6
Installation	7
Creating and recalling scenarios when you have one only Anellum	10
Procedure for setting up rooms with more than one Anellum lamp	11
Creating and recalling scenerios with more than one Anellum lamp	13
Procedure for setting up the Anellum for use in several different rooms in the house	15
Viewing the lamp parameters	17
Automatic demo	17
Timed recall of scenarios	17
Resetting motors	18
Restoring the factory settings	18
Accessories	20
Troubleshooting guide	20
Command summary table	22
Technical assistance	23
Guarantee	24
Manufacturer's CE declaration	24

GENERAL INFORMATION

General safety and maintenance conditions

- Safety is only guaranteed if the device is installed and used appropriately following the instructions given.
- All Anellum devices are suitable for direct assembly on normally inflammable surfaces.
- Any modification made to the device makes null and void the guarantee of conformity to the standards and directives as well as the guarantee described at pag.24.
- Keep these instructions in a safe place so that they may be consulted when necessary.
- The device is to be connected to the power outlet following the instructions given on the label affixed to the lamp.
- Connection of the device to earth is obligatory by law.
- The fuse inside the base is to be replaced exclusively by specialized staff.
- Do not assemble Anellum lamps on a wall or ceiling without using the bracket (to be purchased separately).
- Set up the lamp in a dry and well-ventilated place.
- Avoid exposing the Anellum lamp to excessive damp, rain, sand, heat sources and the direct sunlight.
- Do not obstruct the ventilation slits.

WARNING - DO NOT TOUCH the light bulbs or base, these elements can reach high temperatures

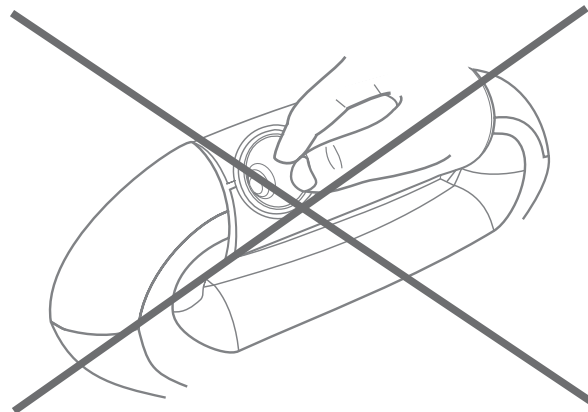

- Keep the lamp out of the reach of children.

- Do not move the moving parts of the lamp by hand, you could damage the electric motors of the Anellum device.

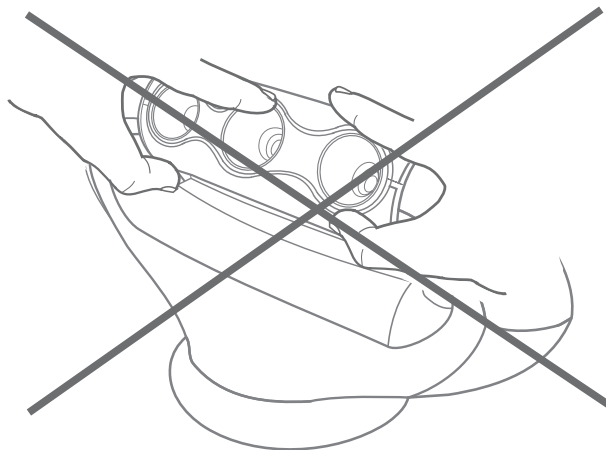

- Only use GU10 light bulbs with a maximum power of 50W. We recommend you purchase OSRAM and BLV (coloured bulbs) products.
- The light bulbs must be situated at a minimum distance of 50 cm from the nearest surface.

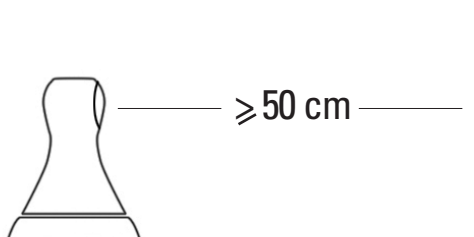

- Use a soft cloth (preferably made of microfiber) to clean the lamp. We recommend you avoid using all chemical detergents. Unplug the lamp from the power outlet before proceeding to clean it.
- The lamps are to be repaired exclusively at an authorized service centre.
- Repairs done in an inappropriate fashion may create a serious risk for the user and make the guarantee null and void.

Conformity to standards

The Anellum device was built in accordance with the EN 60598-1 safety standard and conforms to the applicable European directives (Low voltage directive 73/23 and EMC directive 89/336), see Conformity CE declaration at pag.24.

Disposing of the product

In accordance with the provisions laid down by the European directive 2002/96/EC - WEEE , the lamp is marked with the following symbol, which indicates that the product is to be disposed of separately.



The user of the lamp must dispose of the product and its package in accordance with the local regulations in force.

Description of symbols

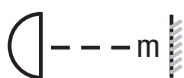

Minimum distance from illuminated object.



Direct mount on normally inflammable surfaces.



Do not use "Cool Beam" lamps.



Use lamps equipped with a protective screen.

PRODUCT DESCRIPTION

Characteristics of the illuminating device

Technical specifications

- Rated voltage: 230-240V AC
- Rated frequency : 50 Hz
- Maximum power : 200 W
- Working temperature: 5°- 30°
- Use: equipment for use in a closed environment (indoor use)
- Type of assembly: on desktop or, using the special bracket (to be purchased separately) on a wall or ceiling

Dimensions (mm.)

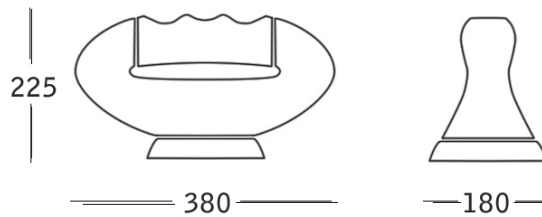

Weight: 2,5 Kg.

CONTENTS OF THE PACKAGE

- 1 Anellum lamp
- 1 remote control *
- 3 50W GU10 bulbs - aluminium reflector
- 2 AA alkaline batteries *
- 1 instructions manual
- 1 quick installation guide
- 1 suction cup

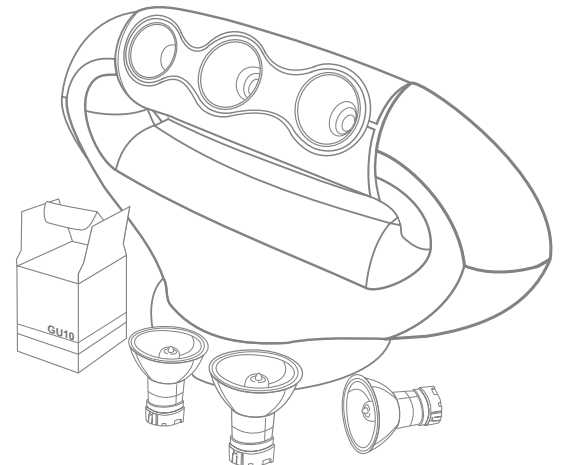

* only present in special packagesi

INSTALLATION

Insert batteries

- Remove the plastic cover on the back of the remote control

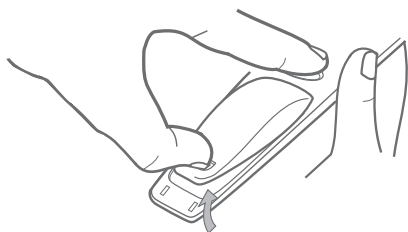

- Insert the two type AA batteries respecting polarities

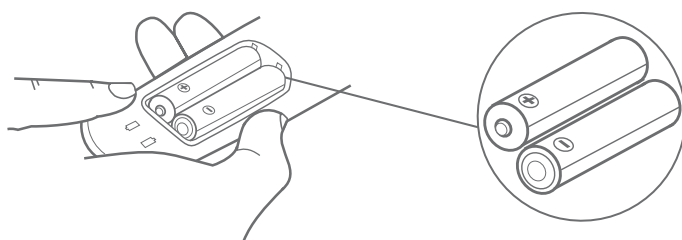

Insert light bulbs

WARNING

Unplug before to proceed with this operation.
Do not rotate manually the parts wich are moving.
Do not touch with your fingers the bulbs lenses.



- Insert the 3 lamps GU10 (max 50 W) using the suction cap in the package.
Put the coloured lamp in the centre

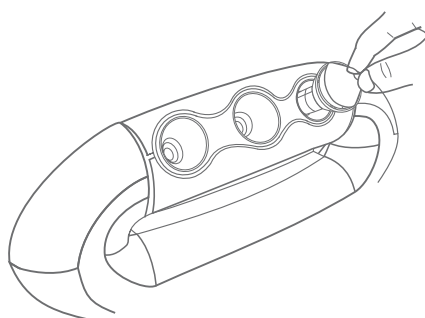

- Once inserted, rotate lightly clockwise until blocking

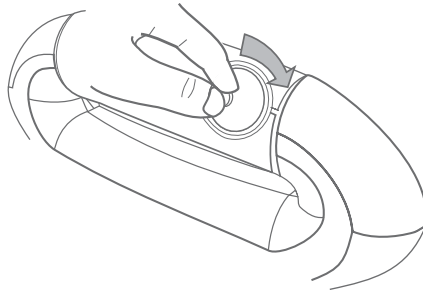

Insert plug

- Put the plug in the socket

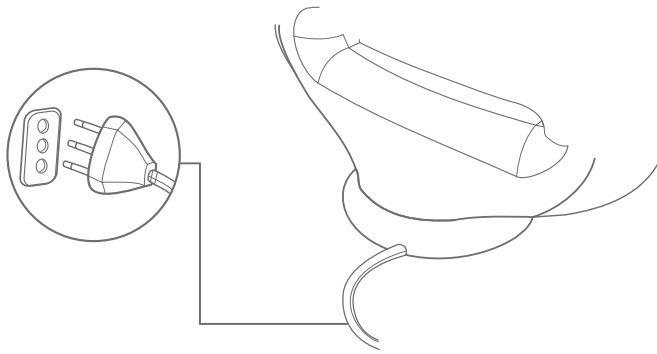

- After having inserted the plug, the lamp will rotate automatically for about 15 seconds, (a slight mechanical noise during the initializing phase is normal), wait for the end of this phase

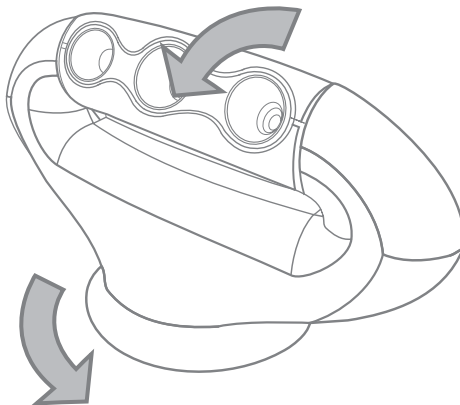

WARNING - The initializing phase takes place only after having put the plug in the socket.



Turn on

Press a button from 0 to 9 to recall a scenery , the Anellum moves and lights up to reproduce one of the scene set up before.

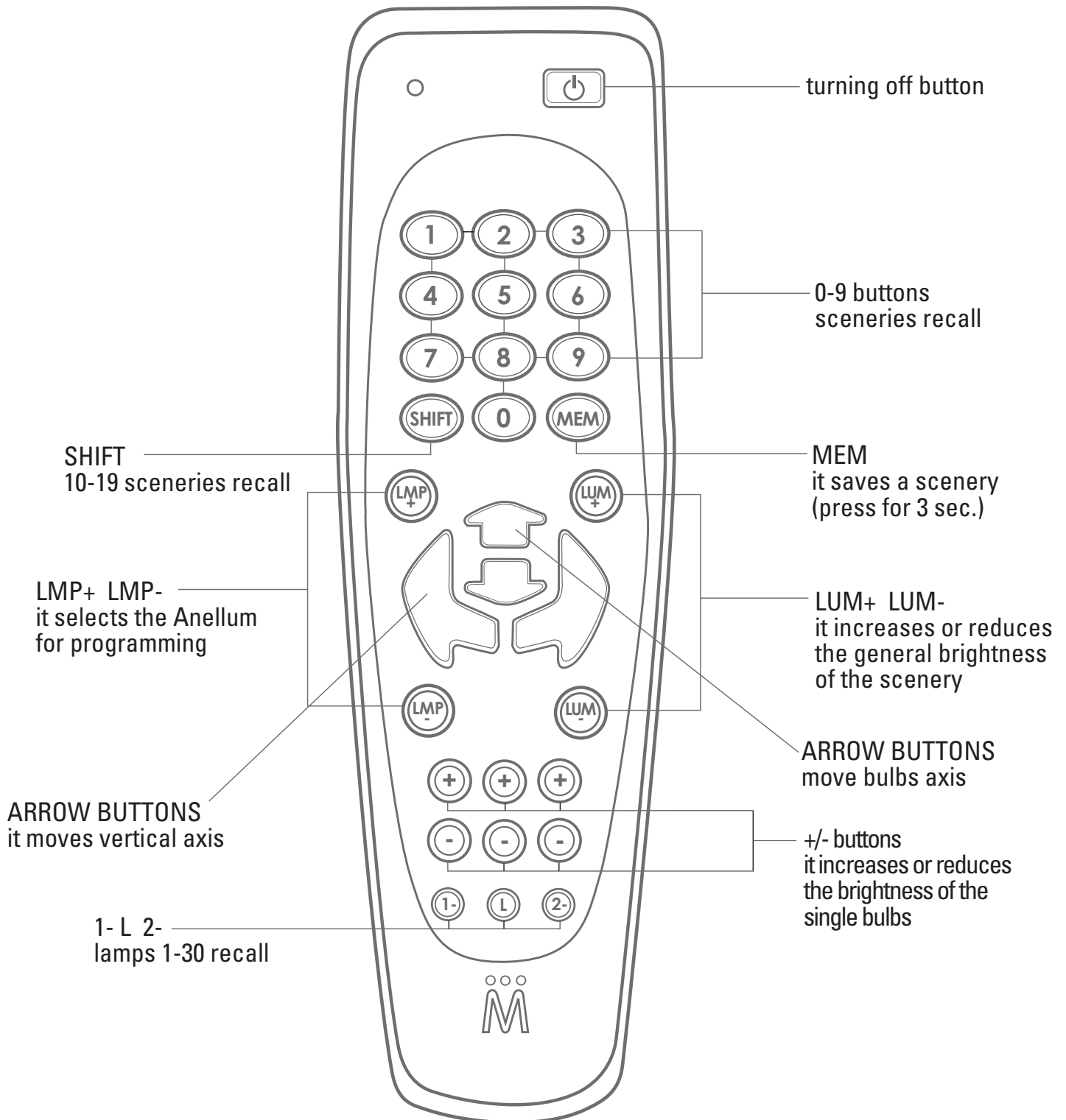

WARNING - If you have more MUVIS lamps see page 11



CREATION AND SCENERIES RECALL WHEN YOU ONLY HAVE ONE ANELLUM

A scenery is the bright environment created by the position and by the luminous intensity of one or more Muvis lamps. Each Anellum lamp can save up to 19 different scenerios, to create them, simply follow this procedure:

A select the scenario you wish to create

for scenarios from 1 a 9 press a key from **1** to **9**

for scenarios from 10 a 19 press in succession **SHIFT** + key from **0** to **9**

B Rotate the lamp with the arrow keys



NOTE - The position of the lamp can be regulated finely by pressing the arrow keys repeatedly

NOTE - The lamp may be rotate 210° about either of its axes and it stops automatically when it reaches the limit point

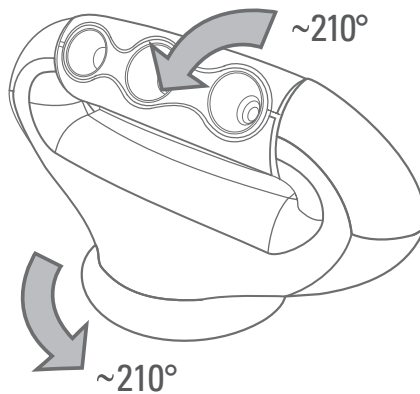

C Increase or decrease the brightness of the three lamps using  keys respectively 

NOTE - By pressing **SHIFT** and  you can set the brightness of the lamp immediately to its minimum and maximum, respectively



D when the position and brightness are as required, press **MEM** for 3 seconds until the Anellum lamp blinks once. The scenario is saved.

E Repeat the procedure for all scenarios you wish to save.

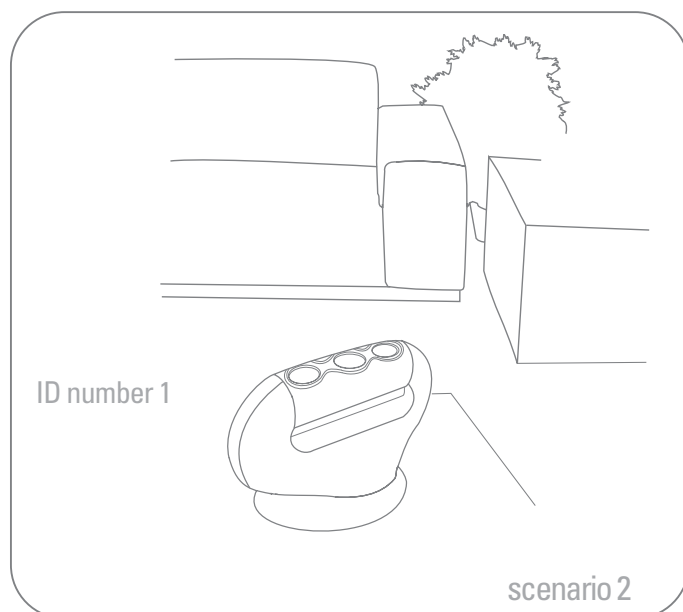
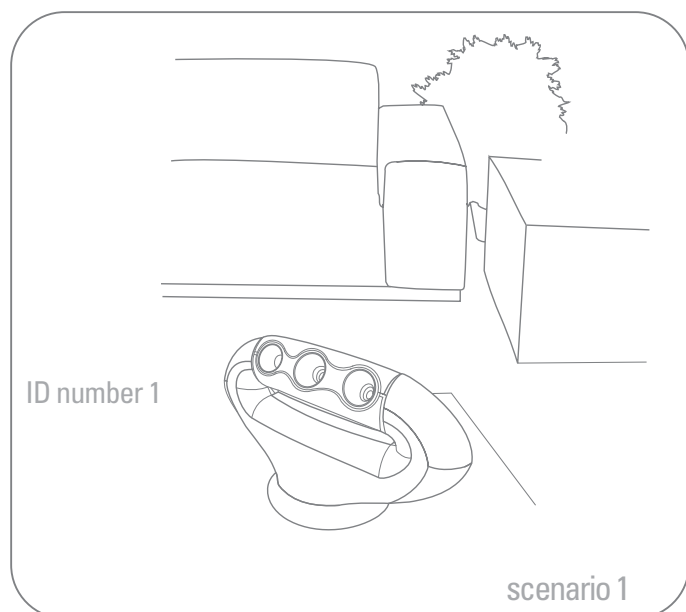

PROCEDURE FOR SETTING UP ROOMS WITH MORE THAN ONE ANELLUM LAMP

In a room with more than one Anellum lamp (you can install up to 128), in order to program the scenarios, each lamp must be assigned an ID number.

NOTE - Each Anellum lamp leaves the factory with the ID number "1" assigned to it and, for this reason, the procedure for assigning a new ID number must be carried out starting from the second lamp

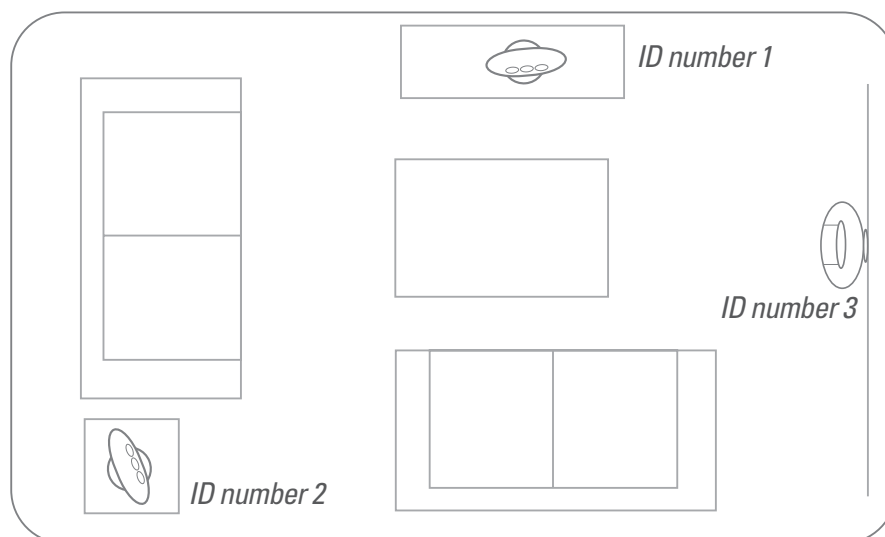

Assigning an identification number

To assign an ID number to each Anellum lamp, proceed as follows:

- detach the plug of the Muvis lamp you wish to program from the power outlet

- press and hold down on the remote control the ID number (from ① to ⑨) that you wish to assign to the Anellum lamp (ex: for lamp 2 press ②)

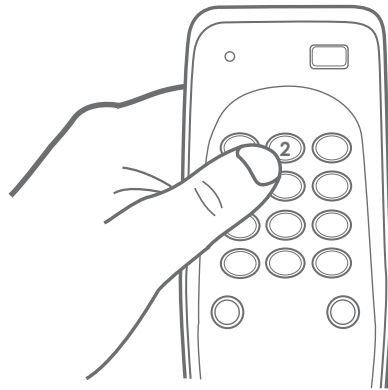

- with the key pressed, reconnect the plug of the lamp to the power outlet and wait for the Anellum lamp to blink once in confirmation

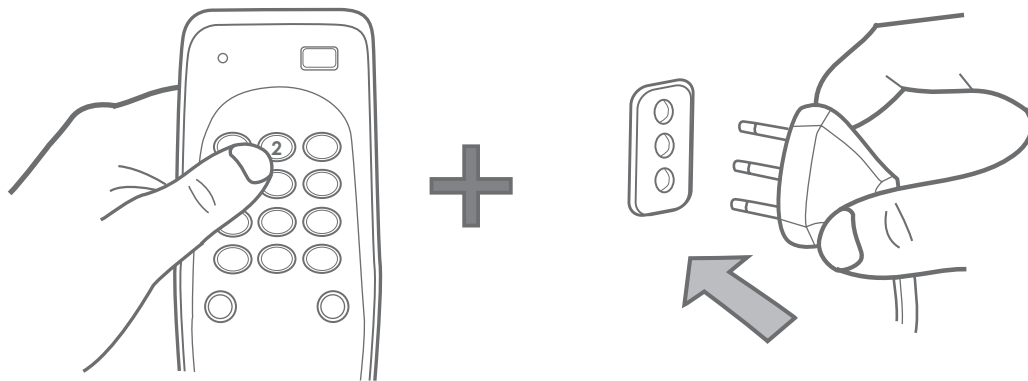

- This procedure is to be repeated for each Anellum lamp present in the environment.

NOTE: this procedure is only valid for lamps with an ID number between 1 and 9, for lamps from 10 to 128, see pag.15



Setting up the remote control

- To create the scenarios, you must be able to select each lamp individually, and to do this you must program the remote control for the number of lamps present in the room:

if, for example, there are 3 lamps in the room, press the **SHIFT** **LMP** **3** in sequence and hold down **3** until the LED on the remote control stops blinking (about 5 seconds)

NOTE - if there are more than 9 lamps, press **SHIFT** **LMP** **0** in sequence and hold down the **0** key until the LED on the remote control stops blinking (about 5 seconds)



CREATING AND RECALLING SCENARIOS WITH MORE THAN ONE ANELLUM LAMP

A scenario is the atmosphere created by the position and brightness of the light beams of one or more Muvis lamps.

Each Anellum lamp can save up to 19 different scenarios and all the lamps present in a room may be controlled from the same remote control.

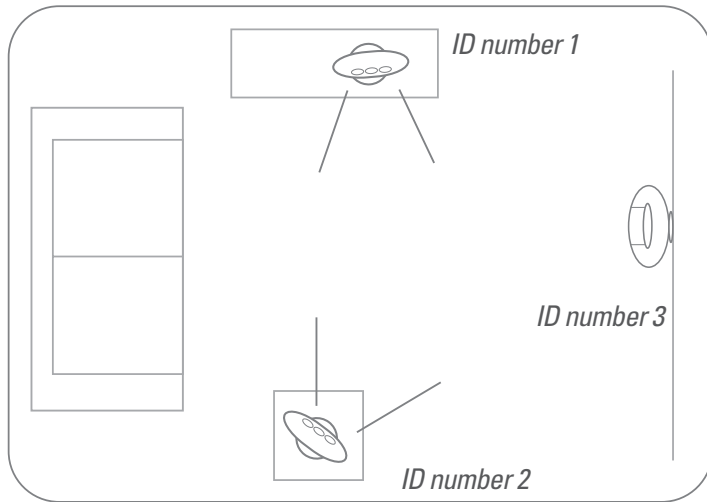

scenario 1

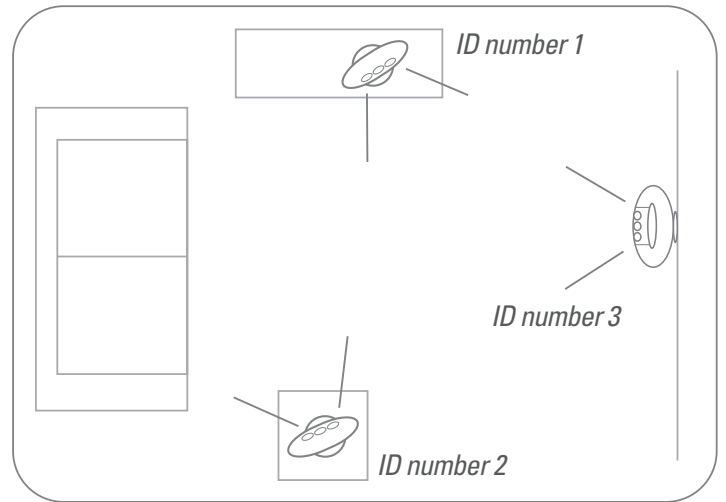

scenario 2

A Selecting a scenario

To create a scenario, you must start by selecting it:

for scenarios 1 to 9, press a key from **1** to **9**

for scenarios 10 to 19 press in succession **SHIFT** + key from **0** to **9**

(ex: **SHIFT** **3** for scenario 13)

B Recalling the lamps

At this point, you must recall all lamps in the room one by one to define their position and brightness and there are two ways of doing this:

method 1 (sequential recall)

By pressing **LAMP** or **LAMP** the lamps present in the room are recalled in sequence, proceed until the lamp you wish to program blinks once

























NOTE - the key **LAMP** performs a "cyclic" function, in other words, when there are, for example, 4 lamps installed, pressing it repeatedly will recall the Anellum lamps in ascending number as follows: 1,2,3,4,1,2,3,4,1...

conversely, the **LAMP** key, when pressed repeatedly, will recall the lamps in descending order and will end at the number "1": 4,3,2,1,1,1,1...



method 2 (direct recall)

You can recall a lamp directly if you know its identification number.

Lamp ID number	Keys sequence	Example
between 1 and 9	 + lamp number	  for lamp 7
between 10 and 19	 + lamp number	  for lamp 15
between 20 to 29	 + lamp number	  for lamp 20
between 30 to 39	  + lamp number	   for lamp 30
between 40 to 49	  + lamp number	   for lamp 43
between 50 to 59	  + lamp number	   for lamp 50

Saving a scenario

By pressing the  keys and the    keys, you can regulate the position and brightness of the lamp selected.

When the orientation and brightness of the three lamps are as desired press and hold down the  key until the lamp blinks once (about 3 sec.). Whenever you recall the scenario that you are programming, the lamp will return to the position that you have just saved.

NOTE - by pressing the  keys lightly, you can regulate the position of the lamp finely



NOTE - the lamp can be rotated 210° about either of the axes and it stops automatically when it reaches the travel end

Repeat the procedure from step **B** to step **C** for each of the lamps present in the room

To create a new scenario, repeat the entire procedure from step **A**

PROCEDURE FOR SETTING UP THE ANELLUM FOR USE IN SEVERAL DIFFERENT ROOM OF THE HOUSE

The Team Light System implemented in the Anellum lamps enables you to use the lamps independently in several different rooms of the house.

You can install, for example, the Anellum lamps in the lounge and in the bedroom to make the rooms autonomous. The remote control of the lounge will only control the lamps present in that room without interfering with those in the bedroom and vice versa. You will obviously need a remote control for each room.

To make the rooms independent, the Anellum lamps must be assigned a different transmission channel for each room. Up to 29 channels can be handled.

Continue by programming all the lamps in each room, assigning each one an ID number and a channel number.

Naturally, all lamps in one room must have different ID numbers but the same channel number.

NOTE - each Anellum lamp leaves the factory with channel 1 preassigned to it

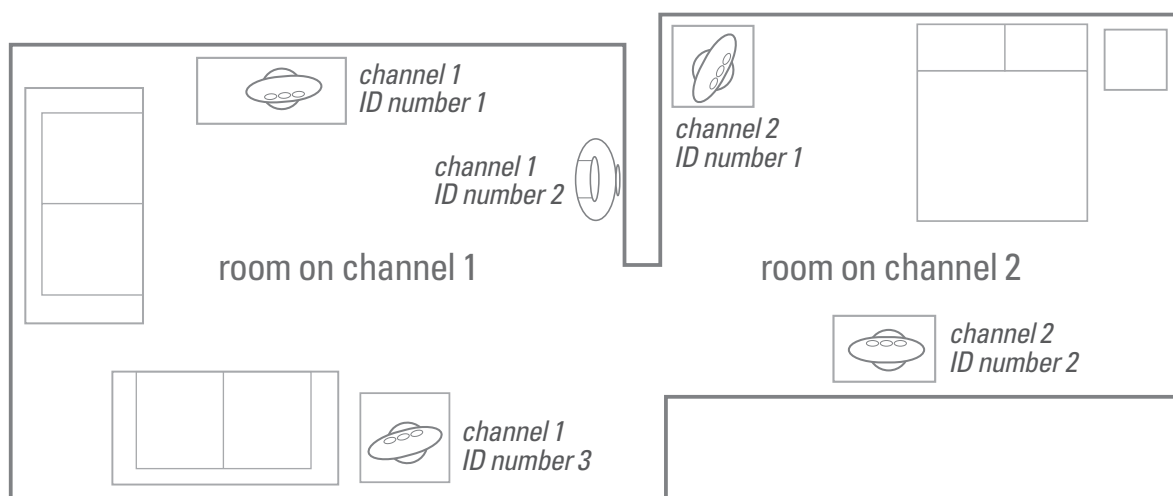

A Programming ID number and channel number:

read the ID code present on the label affixed on the metal base of the lamp

NOTE - you may also view the ID code by means of an Anellum blink sequence, see at page 17



ID CODE
1970

Press keys and simultaneously for 1 second
 Type the ID code of four digits (ex: , , ,)
 Type the 2 digits of the channel to be assigned (ex: ,) for channel 2)
 Type the 3 digits of the ID number to be assigned
 (es: , ,) for Anellum number 3)



At the end of the procedure, if it has been completed successfully, the Anellum lamp will blink once.

NOTE - the procedure is to be completed in no more than 15 seconds, otherwise it will have to be repeated



B Programming the remote control channel

Each remote control present in the apartment must now be programmed on the channel of the room in which it is used.

Remote control channel	Keys sequence	Example
for channels 1 to 9	+ channel number*	*for channel 3
for channels 10 to 19	+ channel number*	*for channel 10
for channels 20 to 29	+ channel number*	*for channel 22

* press the channel number key until the red LED on the remote control is turned off

Now you must program each remote control by indicating the number of lamps present in the room you are in:

for example, if there are 3 lamps in the room, press the keys in sequence and hold pressed the key until the LED on the remote control stops blinking (about 5 seconds).

For creating and recalling scenarios see at page 10

NOTE - if there are more than 9 lamps in the room press in sequence and hold pressed the key until the LED on the remote control stops blinking (about 5 seconds)



VIEWING THE LAMP PARAMETERS

You can view the following lamp parameters by means of the blinks of the central Anellum lamp:

ID number of the lamp

press  and then  +  simultaneously for about 3 seconds

channel number of the lamp

press  and then  +  simultaneously for about 3 seconds

ID code number of the lamp

press  and then  +  simultaneously for about 3 seconds

NOTE - if the lamp is to represent a number made up of more than one digit, (ex: 23), the lamp will blink twice and, after a short pause, another 3 times



NOTE: All the lamps present in the apartment will indicate the parameters requested at the same time

AUTOMATIC DEMO





A short demonstration of all functions of the lamp may be activated by pressing the following key sequence:



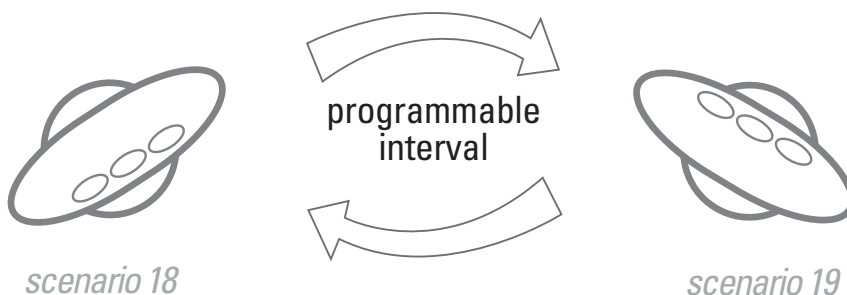

press the  key and then simultaneously   for about 3 seconds.

TIMED RECALL OF SCENARIOS

The system can recall two of the 19 scenarios saved at programmed intervals. All the lamps present in the room will shift at regular intervals between the light atmosphere scenarios saved under scenarios 18 and 19.



save the first of the two desired configurations under scenario 18 (see at page 10)
save the second of the two desired configurations under scenario 19 (see at page 10)
Press the  key and then   simultaneously, then hold pressing for 3 seconds  to  key to choose the interval

-  2 minute interval
-  5 minute interval
-  10 minute interval
-  30 minute interval
-  60 minute interval

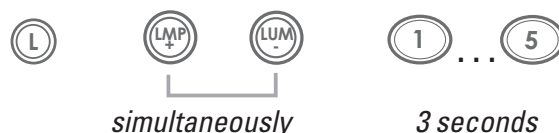

To terminate the timed recall of scenarios, press the key 

The timed recall of the scenarios ends automatically after 8 hours of continual use



NOTE - if the lamps are in scenario 18, when the timed recall is executed, the Anellum lamps will not start moving until the first time interval chosen has passed



RESETTING MOTORS

If the lamps knock against an obstacle or are inadvertently turned by hand, to ensure they function correctly, you must reset the lamp motors.

The procedure is identical to the one to be followed when the plug of the lamp is connected to the power outlet.

Press the  +  keys simultaneously to reset the motors of the lamp currently selected.

Press the  +  keys simultaneously to reset the motors of all lamps on the channel.

NOTE - it is normal that the lamp moves slowly and makes mechanical noises during some phases of the procedure



RESTORING THE FACTORY SETTINGS

By means of this simple procedure, you can restore the default settings made by the manufacturer, and the Anellum lamp is reassigned:

- ID number 1
- transmission channel 1

To restore these settings, perform the following operations:

- detach the plug of the Muvis lamp you wish to program from the power outlet
- hold down the  key on the remote control

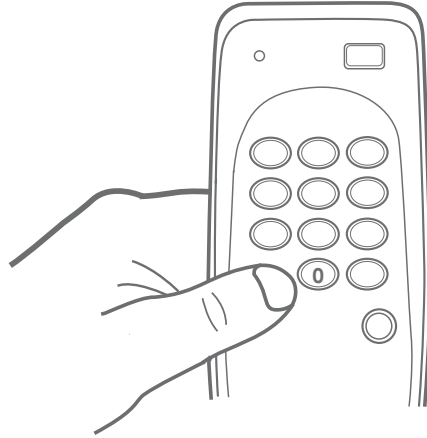



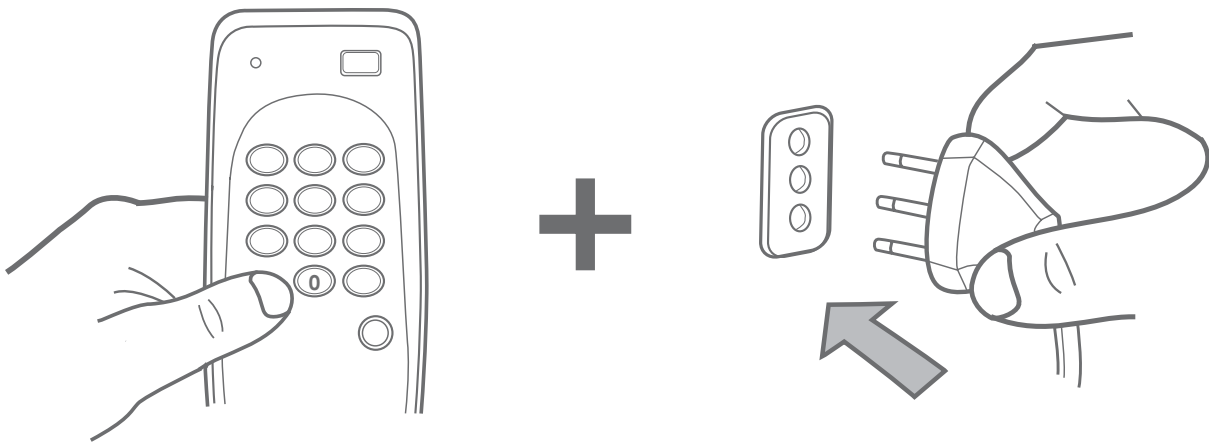



- while you are holding down the  key, reconnect the plug of the lamp and wait for the Anellum lamp to blink once in confirmation



NOTE - the procedure does not remove the scenarios saved by the user



- press the    keys in sequence and hold down the  key until the LED on the remote control stops blinking (about 5 seconds)
- When you press the  or  keys, the Anellum lamp will respond to your commands.

ACCESSORIES

Bracket AN1000

for installing Anellum lamps on a wall or ceiling

Magic Box

The "magic box" that will enable you to include lamps already present in the room in the scenarios: table and free standing lamps, etc.

Having connected them to the Magic Box, they will be turned on and their brightness will be regulated in harmony with the MUVIS lamps.

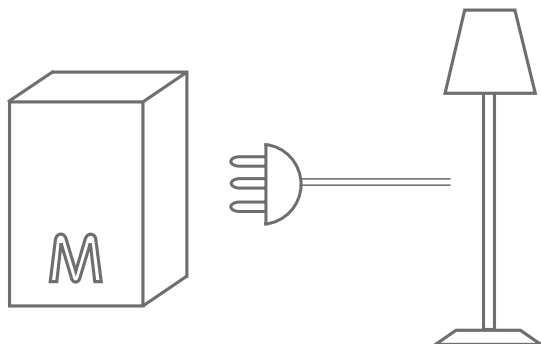



Remote control

Supplementar remote control useful when the Anellum are in different rooms of the house.

TROUBLESHOOTING GUIDE































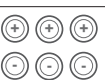

















Failure	Try this
The lamp does not respond to any command	<ul style="list-style-type: none">● Make sure that the Anellum lamp is correctly connected to the power outlet.● Check that the LED on the remote control lights up when you press the keys, and if it doesn't, check that the batteries are charged.● Check that the remote control transmits on the channel set on the lamp:<ul style="list-style-type: none">- view the channel of the lamp by pressing <i>SHIFT</i> and then <i>LUM+</i> and <i>LUM-</i> simultaneously for about 3 seconds.- set the channel on the remote control, see page 16● Check that timed recall of the scenarios is not set and, if it is, press the "OFF" key to return to normal mode.● Try disconnecting the plug, waiting for 10 seconds and then connecting the Anellum to the power outlet again. If the lamp remains immobile and does not execute the initialization procedure, the fuse under the metal base of the lamp will probably have to be replaced (this operation is to be performed by specialized staff). In this case, check to see if any of the light bulbs have blown, in some cases, when a light bulb burns out it may generate overcurrents that cause the fuse to blow. <p>To minimize the risk of these problems arising, only use light bulbs of a high quality.</p>

Causa possibile	Possibile soluzione
The lamp recalls the scenarios but does not respond to the 	The remote control is not addressing the lamp you want to program: - recall it by pressing the LMP+ key repeatedly until the Anellum lamp blinks once or - view the ID number of the lamp by pressing SHIFT and then LMP+ and LMP- simultaneously for about 3 sec. Recall the lamp directly, see page 14
When you press   the lamp does not move or stops after a few seconds	This is normal, you have probably reached the limit point, so press the opposite arrow key
The lamp sometimes stops unexpectedly and emits mechanical sounds	The Anellum lamp has probably been moved by hand and has lost its position references, the "reset motors" procedure must be carried out, see page 18
You cannot stop the timed recall of scenarios	You must press the "OFF" key to return to normal mode
I have two or more Anellum lamps but I cannot program them individually, when I press the arrow keys, they all move at the same time	You must assign the lamps different ID numbers, see page 11
I have two or more Anellum lamps and they have different ID numbers but I can't program them at all	Check that you have carried out the "setting up the remote control" procedure correctly, see section page 12
I have several Anellum lamps mounted in different rooms and the remote control of one room operates the lamps installed in another room of the apartment	You must assign the Anellum lamps a different transmission channel for each room, see page 15
I have trouble activating functions that entail pressing more than one key in sequence	Take care to follow carefully the instructions which tell you to press the keys "in sequence" or simultaneously In a key sequence, you must not let more than 2 seconds pass between pressing one key and the next
Timed recall of the scenarios is interrupted after a few hours	This is normal, timed recall terminates automatically after 8 hours
When I insert the plug of the lamp in the power outlet, the Anellum moves on its own for about 20 sec. and does not respond	This is normal, the Anellum lamp is executing its initialization routine, a procedure that is indispensable for the correct functioning of the lamp
What happens when there is a black-out?	When power is restored, the Muvis lamps present in the apartment execute the initialization routine and will remain off
Can I assemble an Anellum on the wall or ceiling?	The Anellum lamp is designed to be mounted in these positions but you will need a bracket which you must purchase separately, see page 20. Remember that wall or ceiling installation must be executed by specialized staff

If your problem is not on this list, please send us a mail at: customercare@muvis.com or visit the website www.muvis.com

COMMAND SUMMARY TABLE

The "KEYS" columns list the keys to be pressed in sequence the last of which is to be held down for the time indicated in the Time column. The keys that are to be pressed simultaneously are listed in the same cell of the table.

Keys 1	Keys 2	Keys 3	Keys 4	Time	Description
					Turns off lamps
 ... 					Recalls scenarios 1..9
	 ... 				Recalls scenarios 10..19
				3"	Saves scenario on addressed lamp
		 ... 			Saves scenario 1..9
			 ... 		Saves scenarios 10..19
					Moves lamp
					Recalls next lamp
					Recalls previous lamp
					Increases brightness of all lamps on the channel
					Decreases brightness of all lamps on the channel
					Increases/decreases brightness of light bulbs
					Maximum/minimum brightness of light bulbs
	 ... 				Selects lamp 1..9
	 ... 				Selects lamp 10-19
	 ... 				Selects lamp 20-29
		 ... 			Selects lamp 30-39
		 ... 			Selects lamp 40-49
		 ... 			Selects lamp 50-59
			 ... 	5"	Programs remote control on channel 1..9

Keys 1	Keys 2	Keys 3	Keys 4	Time	Description
			...	5"	Programs remote control on channel 10...19
			...	5"	Programs remote control on channel 20...29
		...		5"	Programs max no. lamps managed by remote control
				3"	Shows the ID code
				3"	Shows the lamp ID number
				3"	Shows the channel number
	4 digits ID Code	2 digits channel	3 digits ID number		Programs n° channel - ID number
+				3"	Resets selected lamp motors
+				3"	Resets channel lamp motors
				3"	Automatic demo
		...		3"	Activates timed recall of scenarios

TECHNICAL ASSISTANCE

If the indications given in the "Troubleshooting Guide" section are not sufficient to enable you to solve the problem you have with the lamp, send a mail to:

customercare@muvis.com

you will be called back promptly by our engineers to solve the problem you have with your Anellum lamp as quickly as possible.

For further information, please visit our Website at the address:

www.muvis.com

GUARANTEE

This lamp is guaranteed against defects under normal conditions and in respect of the instructions for installation and use given in this manual, for a period of two years starting from the date of purchase, demonstrated by the proof of purchase (receipt).

Within this period, if the product stops working or works in a way that does not conform to the characteristics declared and guaranteed due to a manufacturing defect or a defect of the materials used at the factory, it will be repaired so that it conforms or will be replaced, in any case, free of charge to the customer. The guarantee does not cover defects deriving from improper or incorrect use of the product, any modifications made to the product by the customer and/or installation not conforming to the instructions given in this manual. To apply the guarantee, you must take or send the product back to the salesman, or one of the customer service centres indicated at www.muvis.com together with the proof of purchase.

The product will be repaired or replaced within a reasonable time of the request, though delays may take place due to temporary unavailability of the product or material.

Please keep the original of the proof of purchase (product receipt) in a safe place.

Memo

Room n° _____

	Description	ID Code	Channel number	Identification number
Lamp 1				
Lamp 2				
Lamp 3				
Lamp 4				
Lamp 5				
Lamp 6				
Lamp 7				

Room n° _____

	Description	ID Code	Channel number	Identification number
Lamp 1				
Lamp 2				
Lamp 3				
Lamp 4				
Lamp 5				
Lamp 6				
Lamp 7				

MANUFACTURER'S CE DECLARATION

The "Anellum" lamp
is conforms to the provisions laid down by the following community directives
(including all the applicable amendments)

Low Voltage Directive 98/37/EEC, amending directive 93/68/EEC;
EMC directive 73/23/EEC, amending directives 92/31/EEC and 93/68/EEC

all the technical standards and/or specifications have been applied:

reference to the regulations and/or technical specifications, or parts of them,
used for this conformity declaration:

Harmonised standards:
EN 60598-1 Luminaires –Part 1: General requirements and tests

Milan, 21st November 2005